



**LASZLO SANDOR
DESIGN**

**MARKENDESIGNER,
GRAFIKDESIGNER,
VERPACKUNGSDESIGNER**

PORTFOLIO

2021



Einführung

HALLO!



Mein Name ist Laszlo Sandor und mit meiner fast 20-jährigen Berufserfahrung als Werbegrafiker stehe ich Ihnen nicht nur für PRINT- und ONLINE-Grafikdesign zur Verfügung, sondern auch für die Erstellung anspruchsvoller Objektfotos und Verpackungsvisualisierungen oder sogar für die Gestaltung einzigartiger Fahrzeugdekorationen.



Bitte werfen Sie einen Blick auf mein Portfolio, um sich ein Bild von meinem Grafikdesign-Stil und der Qualität der Arbeit zu machen, die ich für meine Kunden geleistet habe. Für weitere Informationen und Referenzen besuchen Sie bitte meine Website: <https://laszlosandor.wixsite.com/a-brandfelelos>

„Gerne trage ich auch mit meinem Perfektionismus und meinem Fachwissen zum Erfolg Ihres Unternehmens bei!“

Mit freundlichen Grüßen,

Laszlo Sandor
DER MARKENMANAGER



LOGO-DESIGN

LASZLO SANDOR
DESIGN

THE
BUSINESS
PORT
RAITS



PROFIT7.HU
KIS- ÉS KÖZÉP
VÁLLALKOZÁS HÍRADÓ

Monikas
KINDERWELT

More
than 25
years
experience Est. 1994



VeloChair™
GENEVA

to GODÁNY
TAMÁS

SZEMETELJ
KOSANI!

ga Gaál
Angelika

BONUS+

[G] cseke eszter
PHOTOGRAPHER

Udvari boldog
Futókör

TudásPiac



Waggy
Tails
Dog Walking & Pet Services

MALOM FOTÓSTÚDIÓ

Slóger
TV

The
great
typographers
PORTRAIT SERIES



REBE
Projekt

NEW YORK
JAZZ
GUIDE
BARS • CLUBS



TradeControl

My
Social
Places

INTARZIAKÉSZÍTŐK
ORSZÁGOS EGYESÜLETE

WOOD
ARTS
INTARZIA
PORTRAITS

GOOD VORTEX
creative community

LUXPACK

SALE, DRINK & WADE THE
LAB

slideXpress
GYERE VELÜNK!

Golyó
motoszerkeiz



MUMA
SMINKMŰHELY

BONUS

ENERGY DRINK

YAZI
CAPITAL
THE ART OF
INVESTMENT
ADVISORY

JOBCAPITAL

REDEI
TÉSENY
TUDOMÁNYOS

WalkingGuru

PoNT

B-EV
MOBIL

PURA VITAL

Q Coffee

MAGYAR
MOTORCSÓNÁK
SZÖVETSÉG

Malom
Fotóstúdió



Talent Port
consulting

ANTIQUES CAFE

Angel
Lina
FACE ART

List Fines
Emlékő
2011 LSA



ÁCS KLÁRA
MEDIÁCIÓ ÉS
RENDSZERTÁPIA

éles
nyelvek

IDENTITY GESTALTUNG



MALDIVES BLUE 03
CMYK: 61/51/80

CORPORATE IDENTITY GESTALTUNG

(LSD)
LASZLO SANDOR
DESIGN



CORPORATE IDENTITY GESTALTUNG



Primary color	100%	80%	60%	40%	20%	CMYK: 00/100/100 RGB: 0/119/187 HEXA: #00799b
Secondary color						CMYK: 00/0/0 RGB: 128/128/128 HEXA: #808080
Background color						CMYK: 0/0/0 RGB: 255/255/255 HEXA: #fff
						CMYK: 100/0/0 RGB: 0/0/255 HEXA: #0000ff
						CMYK: 0/0/0 RGB: 0/0/0 HEXA: #000000

T-shirt colors			
CMYK:	40/50/0	90/30/0	100/30/40
RGB:	144/236/240	0/119/187	84/8/8
HEXA:	#90c0d0	#00799b	#080808

Background color	átlós fehér	motoroszsán	panzió	skibútor	gyógykezelés	családi panzió
CMYK:	0/0/0/0	10/10/0	0/0/100	100/0/0	100/0/0	100/0/0
RGB:	255/255/255	255/255/0	255/0/255	255/0/0	255/0/0	255/0/0
HEXA:	#ffffff	#ffff00	#ff00ff	#ff0000	#ff0000	#ff0000



Helvetica Neue Light
28/30pt
Optical kerning
white color

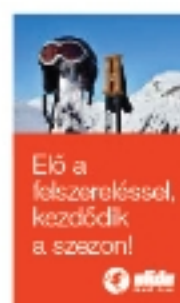

CORPORATE IDENTITY GESTALTUNG



JOB CAPITAL REBRANDING

LOGO REBRAND PLUS CORPORATE IDENTITY GESTALTUNG FÜR 5 GRUPPEN VON UNTERNEHMEN

LASZLO SANDOR
DESIGN



SHAPE



JOB CAPITAL



KEY VISUAL



JOB CAPITAL



JOB CAPITAL

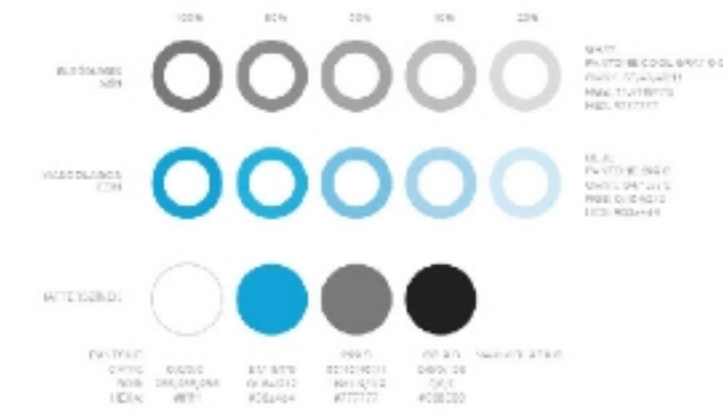

WOOD ARTS BRANDING



RÉDEI REBRANDING

LOGO REBRAND PLUS GESTALTUNG VON ÜBER 76 PRODUKTVERPACKUNGEN

LASZLO SANDOR
DESIGN



Q COFFEE BRANDING

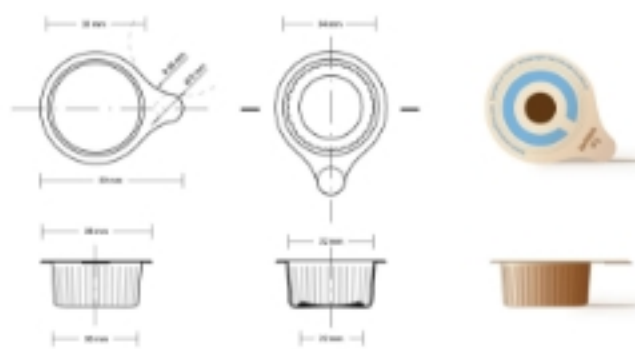

COFFEE
CREAM

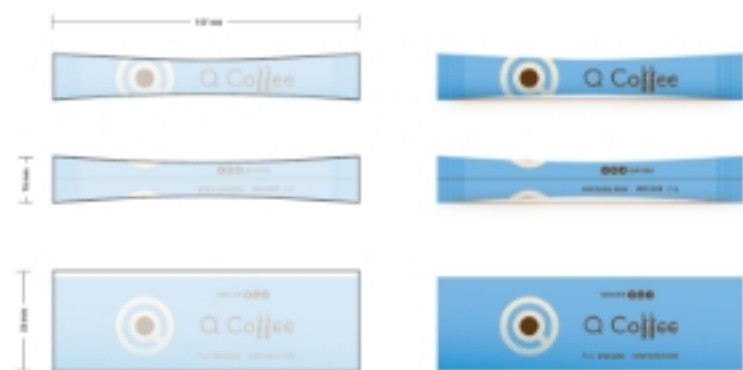

COFFEE
SUGAR



SPECIALITY COFFEE
CAPSULES

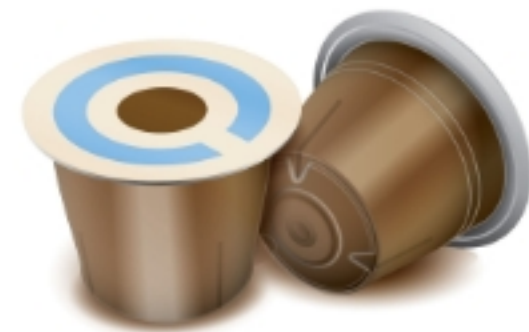

TAKE AWAY
BAG



LASZLO SANDOR
DESIGN



SPECIALITY COFFEE
DRIP PACK

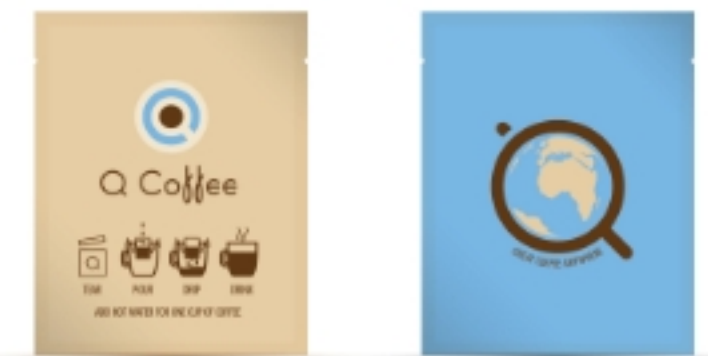

BONUS BRANDING

AUFBAU VIER KOMPLETTEN MARKE, GESTALTUNG VON ÜBER 100 PRODUKTVERPACKUNGEN

 LASZLO SANDOR
DESIGN



HANDBUCH ZUR CORPORATE IDENTITY

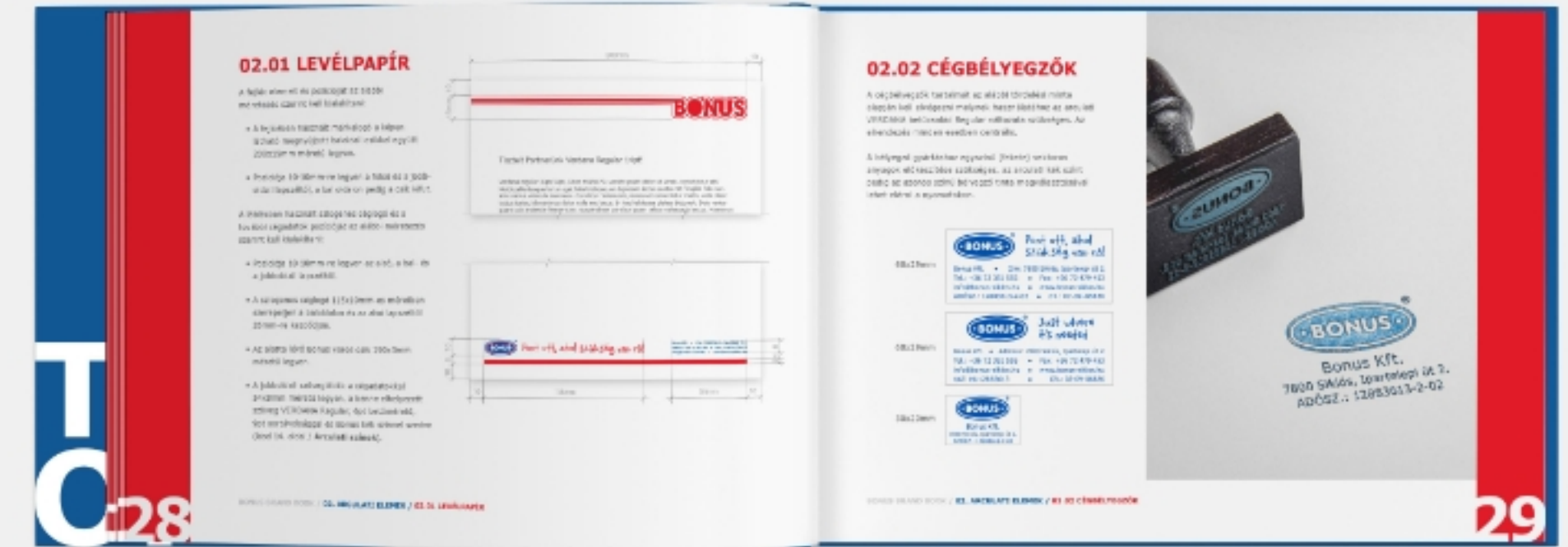

VERPACKUNGSDESIGN

(L) (D) (H)
LASZLO SANDOR
DESIGN



VERPACKUNGSDESIGN

(LSD) LASZLO SANDOR
DESIGN



VERPACKUNGSDESIGN

 LASZLO SANDOR
DESIGN



VERPACKUNGSDESIGN

(LSD) LASZLO SANDOR DESIGN



VERPACKUNGSDESIGN



Sea buckthorn – Moisturizing Cream
50ml-es lís tégely, ezüst pérgelt logó a címoldalon

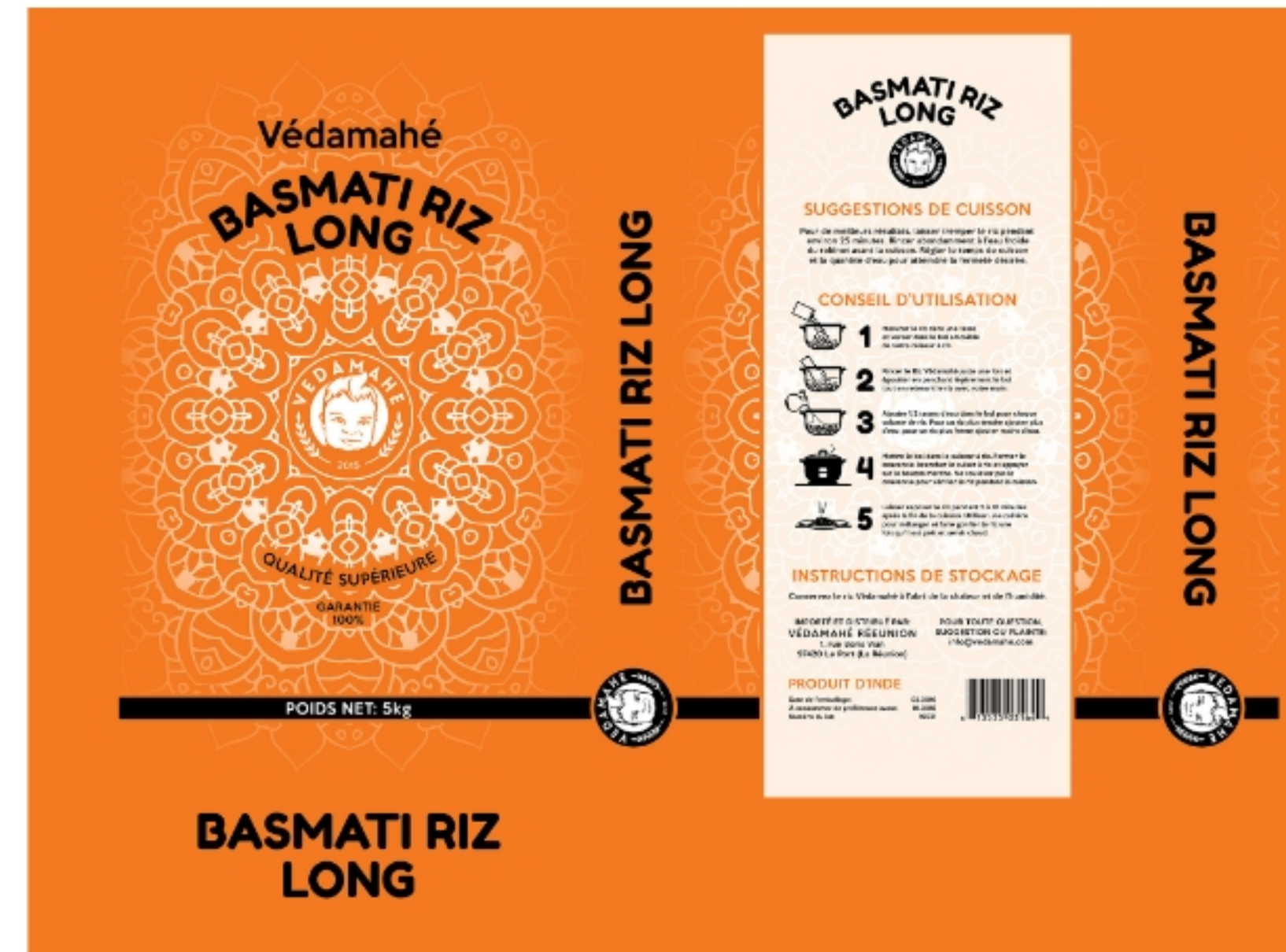

VERPACKUNGSDESIGN

LASZLO SANDOR
DESIGN



DESIGNED TO DELIVER COST EFFECTIVE, DURABILITY & PERFORMANCE.

RICH CLASSIC



INTERIOR/EXTERIOR
ACRYLIC HOUSE PAINT



! Excellent Coverage • Mildew Resistant
! Fade Resistant • Product Versatility • Easy To Apply

AVAILABLE IN #350 FLAT, #360 SATIN, #370 EGGSHELL, AND #380 SEMI-GLOSS



KATALOG- UND MODELLBILDER

(LSD) LASZLO SANDOR
DESIGN



BILDER AUS DER WERBUNG

(L) LASZLO SANDOR
(D) DESIGN



BILDER AUS DER WERBUNG

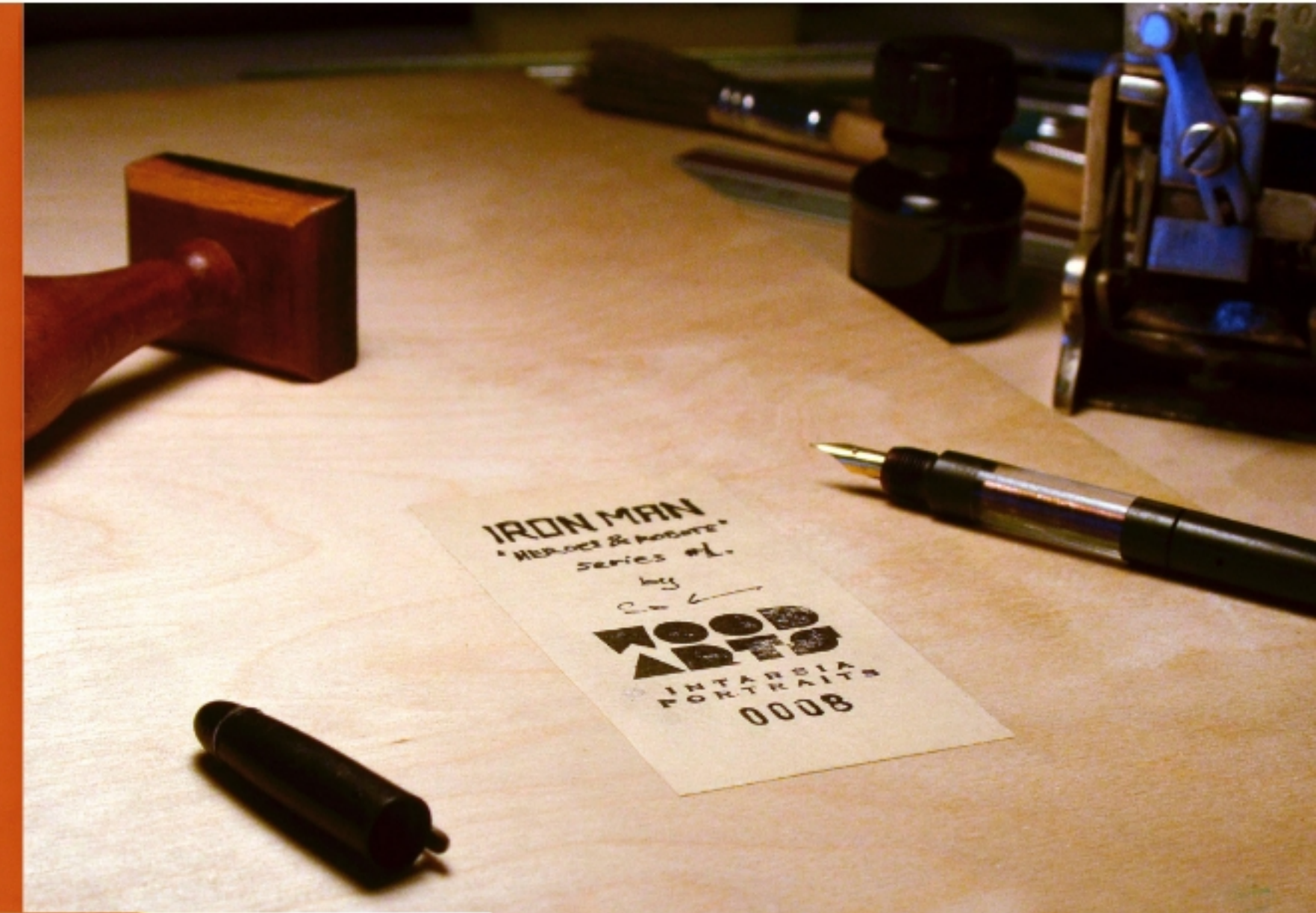

BILDER AUS DER WERBUNG

LESLIE ALEXANDER

Unique jewelry using exotic wood from natural ingredients



The Charm of Nature

LESLIE ALEXANDER

Unique jewelry using exotic wood from natural ingredients



The Charm of Nature

LESLIE ALEXANDER

Marquetry rings using exotic wood



The Charm of Nature

LESLIE ALEXANDER

The Charm of Nature



Wood has always been fascinated by the variety and diversity, its unique character. My works in a variety of wood species and the special atmosphere of my studio combine and become with the special veining, pattern, natural colors of the exotic wood used. The tree species known to me use unique combinations to an exclusive fashion jewelry can wear for any occasion. Each piece is unique and special, because there are no two identical patterns wood panel. Thanks to the jewelry surface resulting play of light in the trees always different hue, so you can not get enough of their beauty.

Unique jewelry using exotic wood from natural ingredients



LESLIE ALEXANDER

Wood has always been fascinated by the variety and diversity, its unique character. My works in a variety of wood species meet the special atmosphere of my studio artworks and belongs to the special veining, pattern, natural colors of the exotic woods used. The tree species known so I use unique combinations to an exclusive fashion jewelry can wear for any occasion. Each piece is unique and special, because there are no two identical patterns wood panel. Thanks to the jewelry surface resulting play of light in the trees always different hue, so you can not get enough of their beauty.

The Charm of Nature

VERPACKUNG VISUELL

(L) (D) (I)
LASZLO SANDOR
DESIGN



VERPACKUNG VISUELL



MOBILE ANWENDUNG

APP ICONS

62x62px 72x72px 114x114px

SPLASH

LAYOUT

ILLUSTRATION

ANIMATION

AVAILABLE...

...ON THE GOOGLE PLAY & APP STORE. COMPATIBLE WITH ANDROID, IPHONE, IPOD TOUCH & IPAD. REQUIRES ANDROID 2.2 & IOS 4.3 OR LATER.

Bringázz a munkába!

FÉNYKÉP BEJELENTŐ AZ ILLEGÁLIS HULLADÉKLERAKÁSRÓL

SZEMETELJ OKOSAN!

EGYSZERŰEN MEGTALÁLHATJA HŐMEZŐVÁSÁRHELYEN A SZÉLETIV HULLADÉKLERAKÓKAT ÉS FOTÓ BEKÜLDÉSSEL SEGÍTHETI AZ ILLEGÁLIS SZEMÉTERAKÓK FELSZÁMOLÁST.

APP ICONS

62x62px 72x72px 114x114px

SPLASH

LAYOUT

ILLUSTRATION

ICONS UP & DOWN

AVAILABLE...

...ON THE GOOGLE PLAY & APP STORE. COMPATIBLE WITH ANDROID, IPHONE, IPOD TOUCH & IPAD. REQUIRES ANDROID 2.2 & IOS 4.3 OR LATER.

A KÖRNYEZETUDATOSÁG ÉRTÉKI



ONLINE- UND PRINTWERBUNG

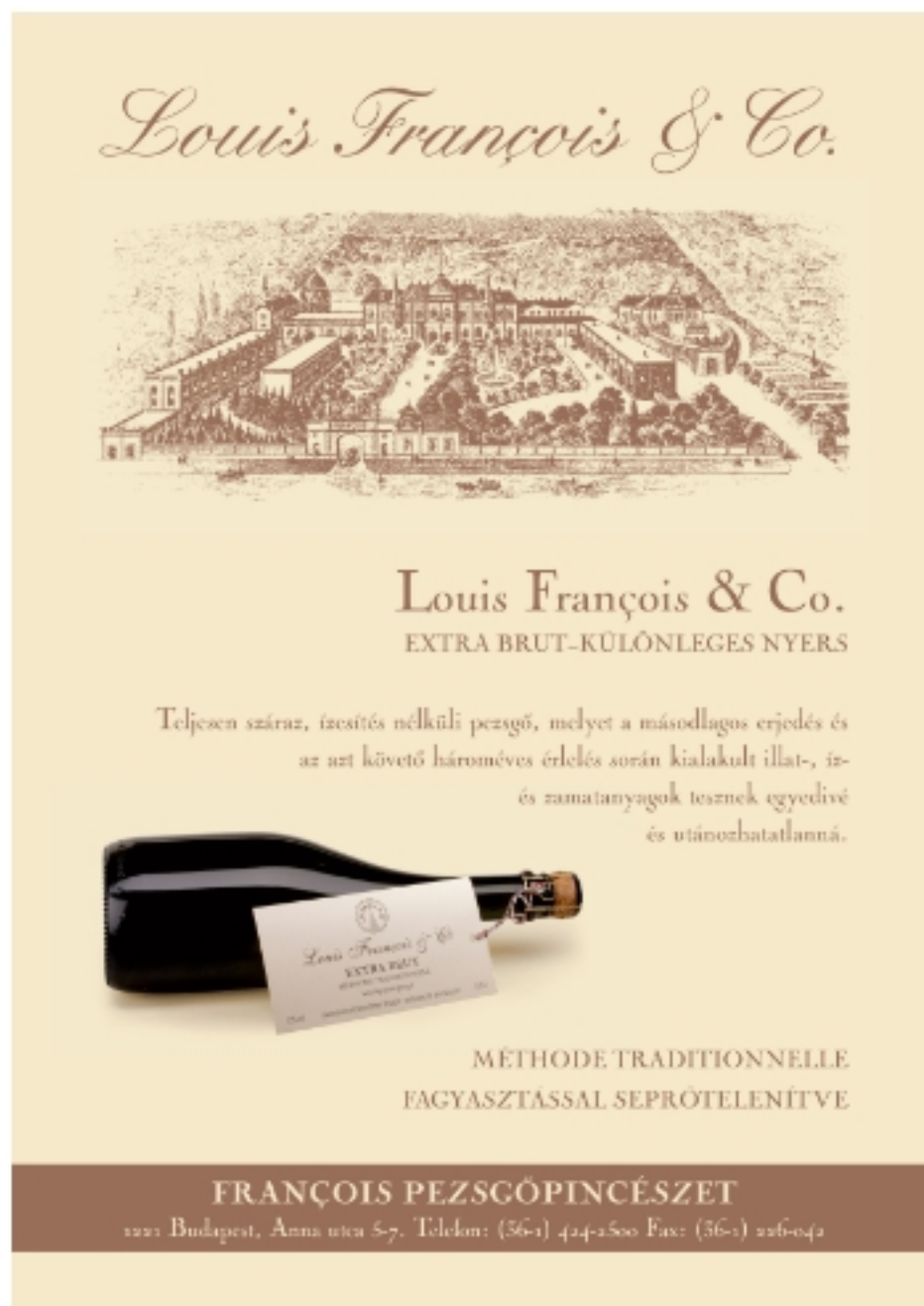

WERBEFILM-PACKSHOT

LASZLO SANDOR
DESIGN

#1

Varilux®
A VILÁG VEZETŐ
MULTIFOKÁLIS
LENCSEMÁRKÁJA*



VOGUE EYEWEAR és
ARMANI EXCHANGE
Komplett dioptriás szemüveg

VARILUX®
szemüveglencsével

30%
kedvezményel

SOLE OPTIKA

www.facebook.com/SoleOptika

Az ajánlat 2021. július 1. és augusztus 15. között érvényes a Sole Optikában.
A részletekről érdeklődjön az optikában, vagy a fenti linken.

*Euromonitor 2019-os adatai alapján, eladási értékben a kiskereskedelmi eladási árak alapján, szemüveglencse kategóriában, multifokális lencsemárkák körében.

BÜCHER

(LSD) LASZLO SANDOR DESIGN

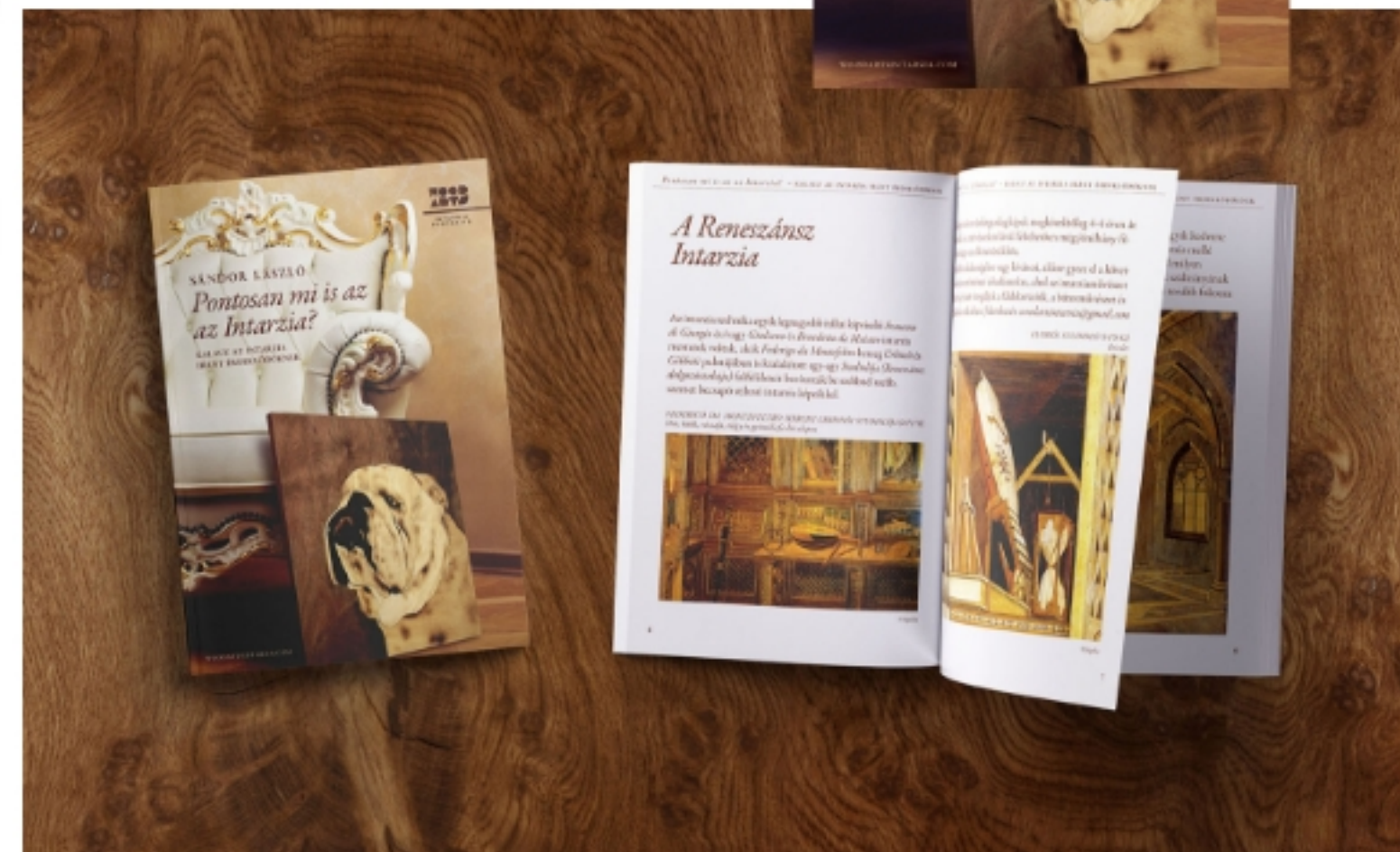
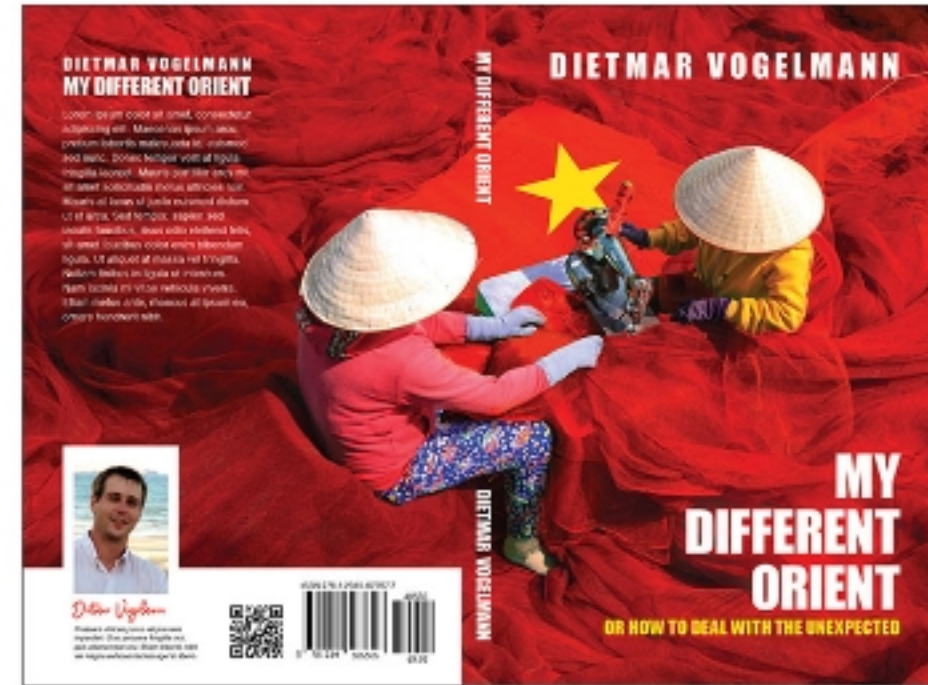
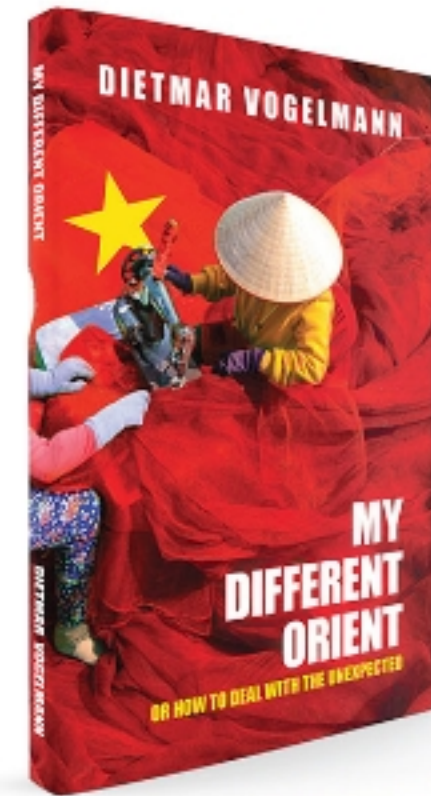

B-EV MOBIIL ELEKTROMOS AUTÓ, AZ ÉRTÉKREND TŰKREI

GESTALTUNG VON PUBLIKATIONEN, KATALOGGESTALTUNG

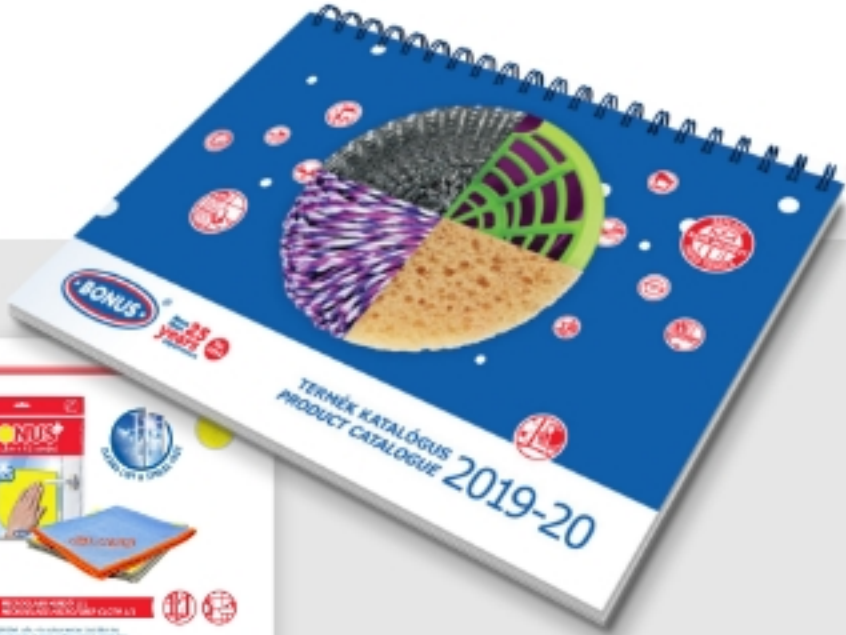

ICONS

CONSEIL

- Mett et ve de v
- Rinc égou tout
- Ajou volu d'eau
- Mett couv sur le couv
- Laiss après pour fois c

TEAR COFFEE CAPSULES

POUR RISTRETTO

DRIP ESPRESSO

DRINK ESPRESSO

Mix it up!
Add 250ml of your beverage of choice to the coffee per scoop of fruit and...

Blend it!
Add 250ml of your beverage of choice to the coffee per scoop of fruit and...

Create!
Mix, Blend and create...

MICRONUTRIENTS

NUTRITIONAL INFORMATION

INGREDIENTS

ALLERGEN INFORMATION

REPLACE SAVE MONEY! PAPER TOWELS

NON Scratch

Absorbs over 12x times its weight!

INOX STAINLESS STEEL

100% Cotton



EGYPTIAN COLLECTION

ANTIQUE COLLECTION

OLD GALLERY

OLD STATUE COLLECTION

POST-1800 COLLECTION

GRAPHIC COLLECTION

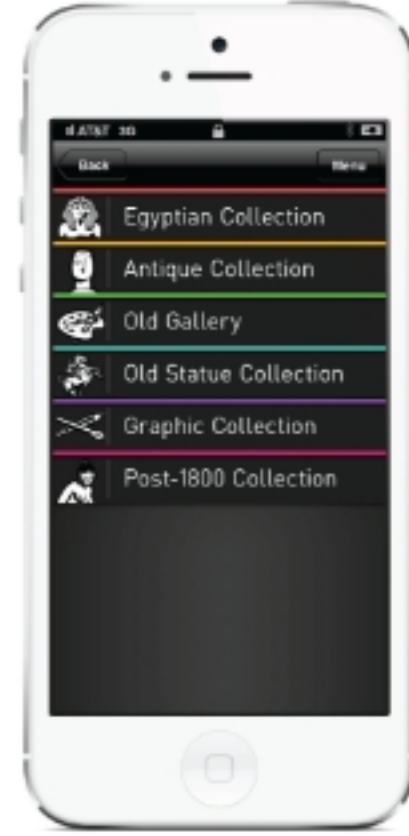

APP ICONS

62x62px 72x72px 114x114px

APP ICONS

62x62px 72x72px 114x114px

GREAT COMFORT + RESISTANT TOILET & BATHROOM

Absorbs over 16x times its weight!

9 ROLLS OF NORMAL PAPER TOWELS REPLACES

SUPER ABSORBENT

DURABLE & ULTRA LONG

DURABLE 38 CM & EXTRA LONG

MULTIPURPOSE USE

ILLUSTRATIONEN

(LSD) LASZLO SANDOR
DESIGN

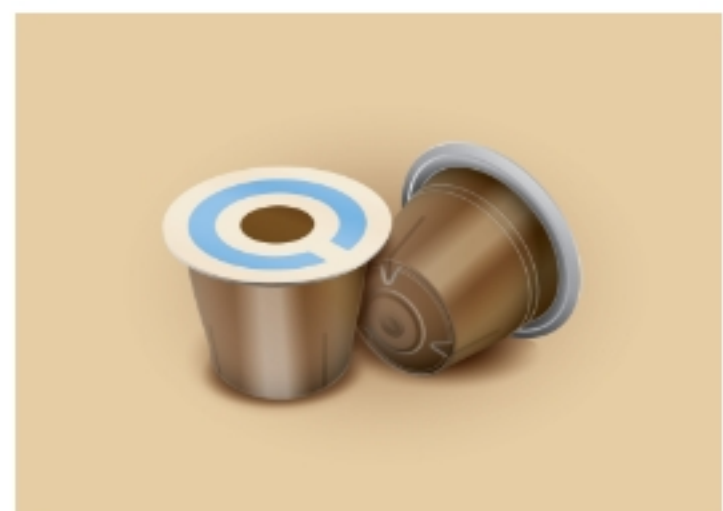
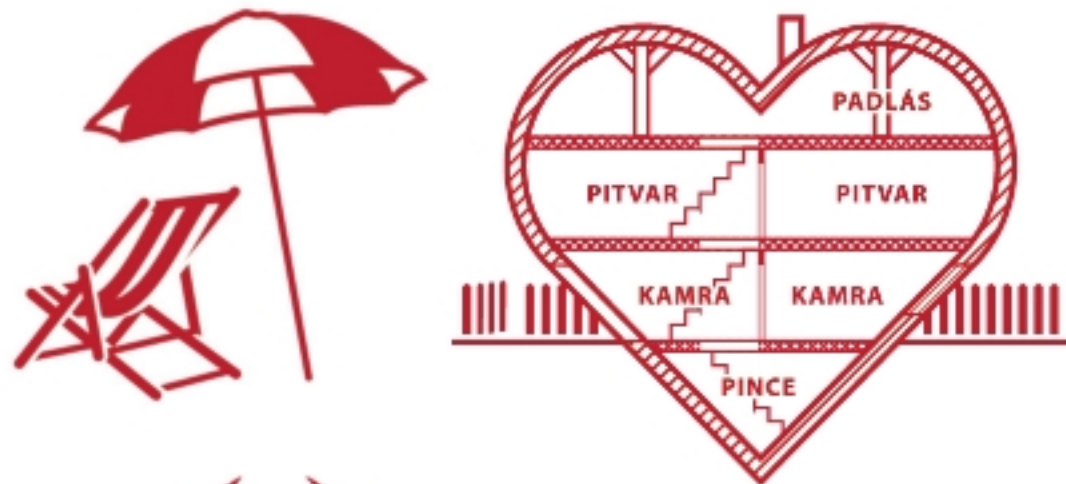
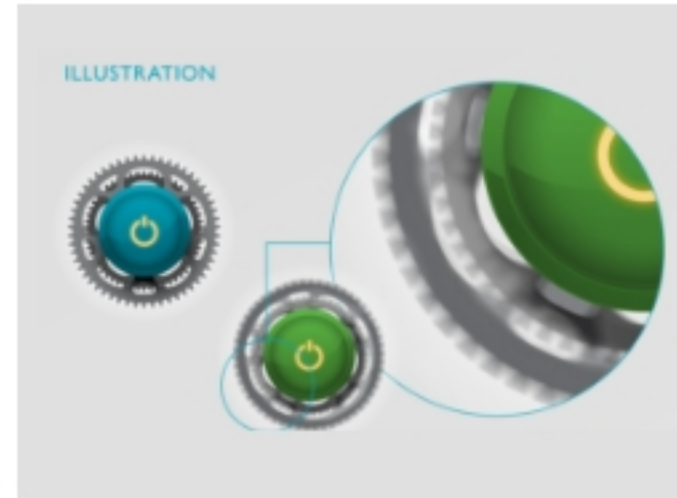

ILLUSTRATIONEN

(LSD)
LASZLO SANDOR
DESIGN

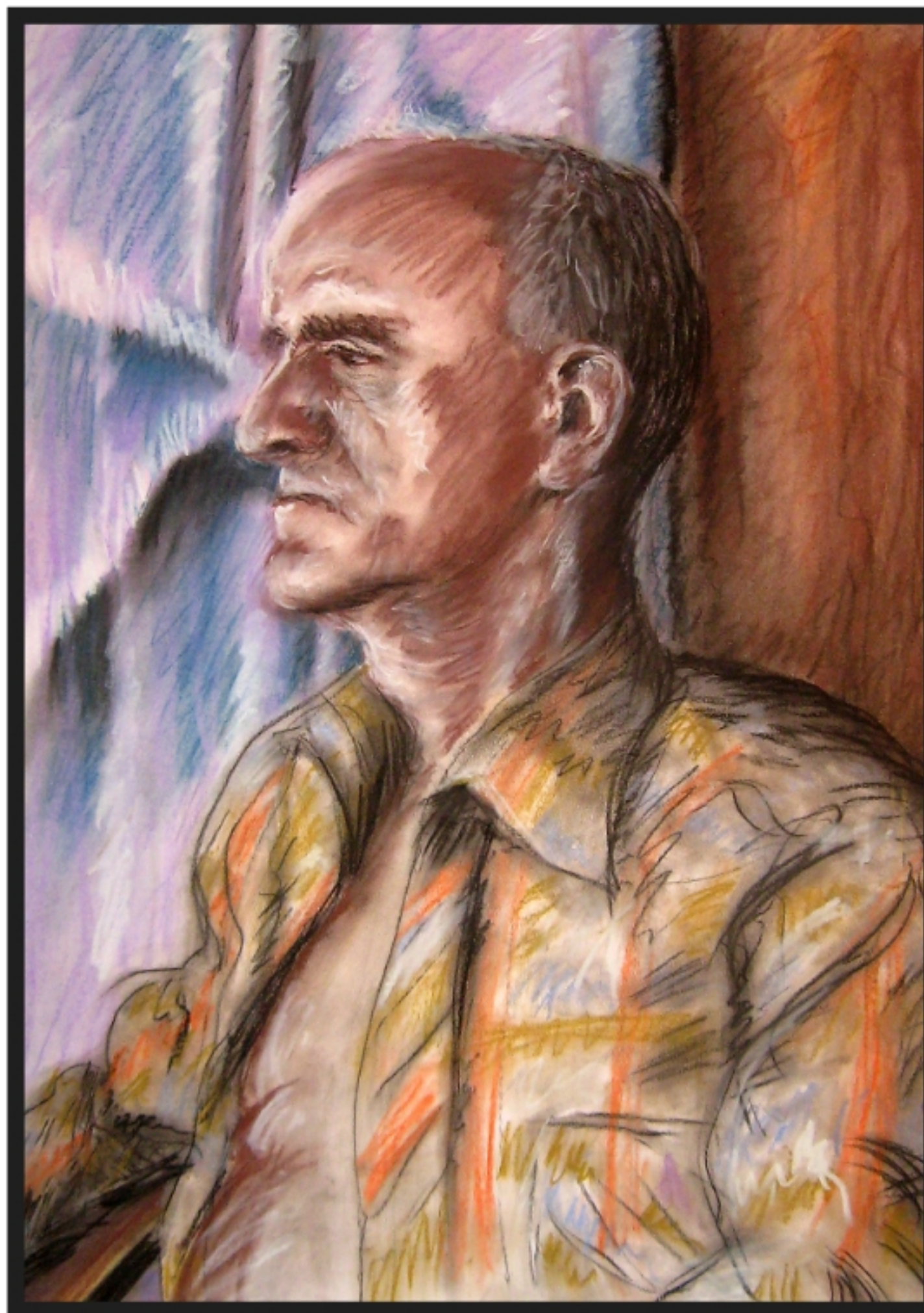
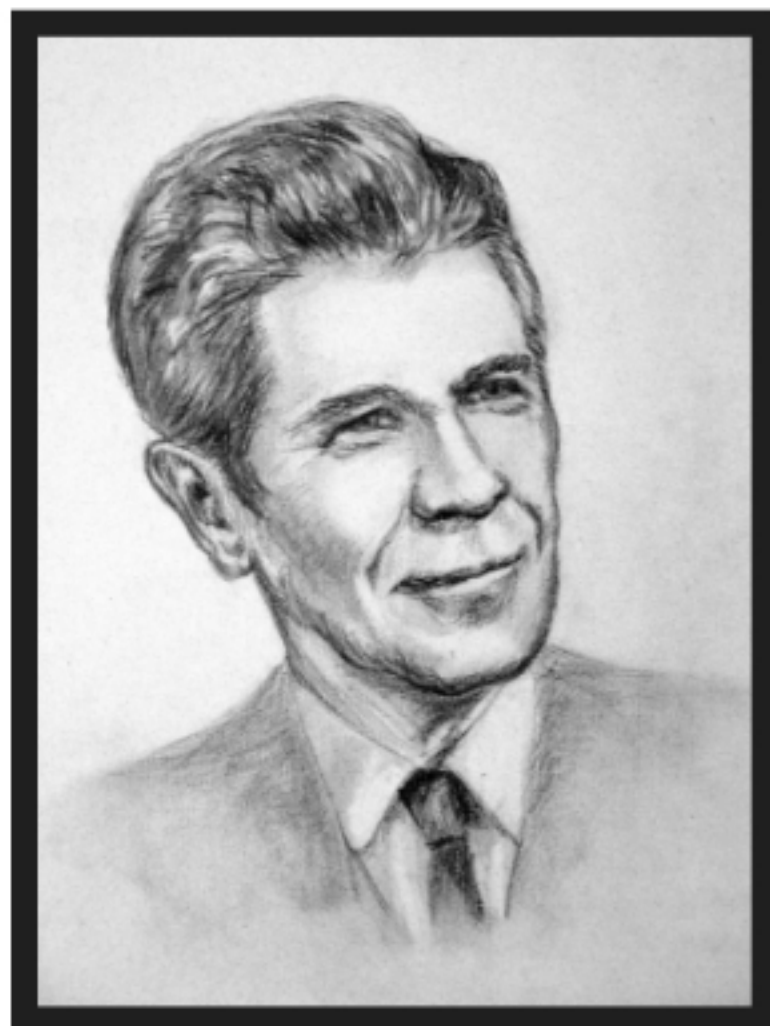

KUNSTWERK

(-|-) LASZLO SANDOR
DESIGN



gift pack

poster series

The great typographers
PORTRAIT SERIES

t-shirts

tote bags

MÖBEL UND KOPFTEIL DESIGN

LASZLO SANDOR
DESIGN



A „BUBBLES” koncepció a furnér burkolatot preferálja. A grafika egyszerűsége lehetővé teszi a formák elhelyezését a tömörfa felületére süllyesztve. Ezt úgy képzeltem el, hogy a furnér vastagságának helyett 0,6-0,9 mm mélyen, marással besüllyesztem a kész bútor felületére, beragasztjuk az adott furnért, majd egybe csiszoljuk az egész felületet. Így a háttér minden esetben megmarad a bútor eredeti színével és textúrájával, de hozzátársítható egy – a megfelelő kontraszt mellett – kiválasztott furnér.

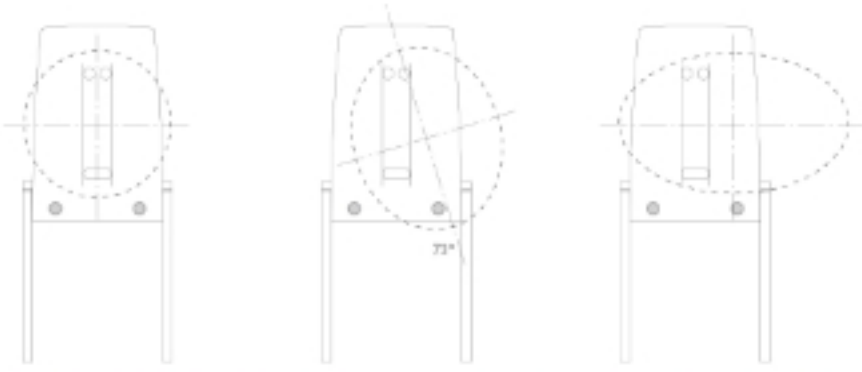

A RANK szék esetében már meglévő alsó nyílás mellett az OTTO ülőkén is használt két lyuk a fülkérülne a háttámlára. Így egységesítve az OTTO-n is használt stílust és egyben megemlékeztetve a buborékokat akik, így már nemcsak az OTTO-n is használt szemekkel, hanem szíjjakkal is bírnának.

Ez a design remek játéklehetőséget rejt a gyerekek és szülei számára is, például kedvesnáló lehet a rosszul evő gyerekeknek. A székeken lévő grafika használható „jelmezként” is, mivel mögöjük bújva megemlékeztetnek az egyes buborékok. Az OTTO ülőkék az oldalukra billentve szintén használhatók maszk vagy paravánként jütek közben, esetleg a mögöhelyezett éjszai lámpával hangulatvilágítás is kialakítható vele a gyermekszobákban.



További természetesenléti lehetőségként textil ülőpárnákat is el tudok képzelni. Ezek a kétyelem felvétel mellett a buborékok felületét imitálják úgy, hogy egy kis felületen „félkiszárad” a háttámla aljára, körülölelve azt, sül, nyakkendő vagy egyéb ruhaszaléként.



Egy teljes sorozat (6-8 székekkel) díszít lehet a családok nappalijának, étkezőjének, egyedi hangulatot kölcsönözve annak. A különböző formák lehetővé teszik, hogy mindenki kiválassza a kedvencét.



Idéltis kanyargó elem, hiszen variálható szín- és forma kombinációkat kínál:

- Különböző formájú buborékok hasonló színű sorozat
- Különböző formájú és színű sorozat
- Azonos formájú, de különböző színű
- Azonos formájú és azonos színű kombináció

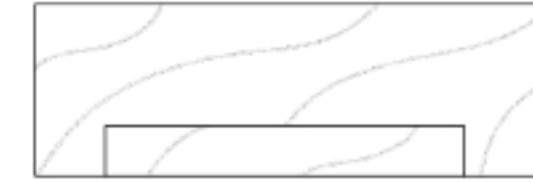

HEAD MOTIFS
Waves

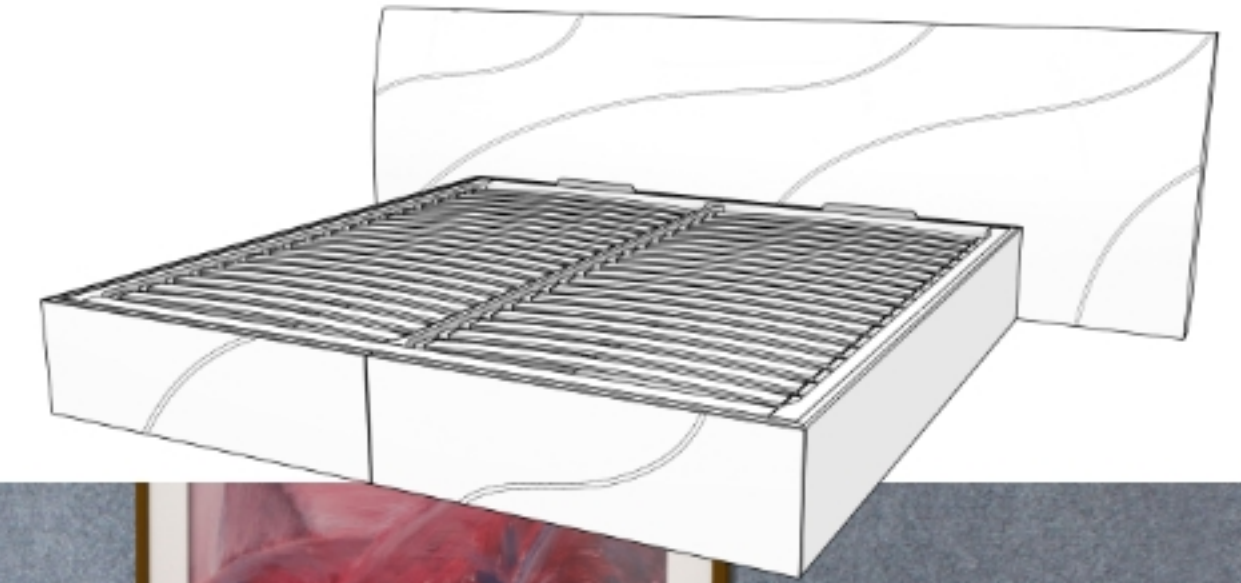

FAHRZEUGGRAFIKEN

 LASZLO SANDOR
DESIGN



AUSSTELLUNGSDESIGN



PREISE UND ANERKENNUNG

2019 Ausstellender und veröffentlichter Intarsienkünstler
ART EXPO NEW YORK – Internationale Kunstmesse und Ausstellung – USA, New York

2018 Ausstellender und veröffentlichter Schmuckdesigner
MAGMA+ Galerie & Design Shop, Burg Buda – Ungarn, Budapest

2018 Dritter Platz: der St Albans Award
– Internationale Intarsienausstellung und Wettbewerb, Vereinigtes Königreich

2018 Hiii Illustration Internationaler Wettbewerb
– Internationaler Illustrationswettbewerb, China, Nanjing

2017 1. Platz: der JACK FLETCHER AWARD
– Internationale Intarsienausstellung und Wettbewerb, Vereinigtes Königreich

2016 Ausstellender und veröffentlichter Grafiker
XX Nationale Biennale für Grafikdesign – MIKSZ, Ausstellungsbuch – Ungarn, Budapest

2016 Kategorie professionelle Verpackungen: die Hiiibrand Awards 2015
– Internationaler Wettbewerb für Logos, Marken und Verpackungen, China

2015 Ausstellender und veröffentlichter Intarsienkünstler
Ungarisches Kunsthandwerk 2015 – AMKA Ausstellung – Ungarn, Budapest

2014 Ausstellender und veröffentlichter Intarsienkünstler – „Eye“ Maple / DESIGN WEEK
– Wood Arts Intarsia Ausstellung – Ungarn, Budapest

2013 Veröffentlichter Grafiker – Veröffentlichung der Posterserie „The Great Typographers“ (TGT)
Brand Magazin „the fashion issue“ 2013 – vol 3, China

2013 Ausstellender und veröffentlichter Grafiker – Start der Posterserie TGT
Ungarische Angewandte Kunst 2013 – 1. Auflage, Ungarn, Budapest

2012 Design und Gestaltung: Gewinner „Grafikdesign des Tages“, Online/Print-Veröffentlichung
– TGT – Auswahl der besten internationalen Grafik- und Produktdesigner, Frankreich

2012 Logopond Book: veröffentlichter Grafiker – Band 1.
– Internationale Logoauswahl Buchveröffentlichung, USA

2012 Finalist in der Kategorie Logo bei den Hiiibrand Awards 2011
– Internationaler Wettbewerb für Logos, Marken und Verpackungen, China

2012 Verpackung Finalist bei den Hiiibrand Awards 2011
– Internationaler Wettbewerb für Logos, Marken und Verpackungen, China

2012 Gewinner des Jury-Preises in der Kategorie Verpackung: Hiiibrand Awards 2011
– Internationaler Wettbewerb für Logos, Marken und Verpackungen, China

2010 Meist gepostete Design „PLETHORA Top 10“ Auswahl: Typo Lampe #10
– Plethora, die iPhone-App, die die besten Designauswahlen zeigt, Neuseeland

2010 Kategorie Grafikdesign 1. Platz: Kreatives Versprechen des Jahres
– BKF-Wettbewerb für visuelle Kunst, Ungarn, Budapest

VIELEN DANK FÜR IHRE AUFMERKSAMKEIT!



 +36 70 340 4099

 laszlosandor75@gmail.com

 <https://laszlosandor.wixsite.com/a-brandfelelos>

Alle Bilder des Portfolios sind das geistige Eigentum von Laszlo Sandor, einem Einzelunternehmer, und seinen Kunden. Jede unbefugte Nutzung der Bilder kann gegen das Urheberrecht, das Markenrecht, das Urheberpersönlichkeitsrecht, das Werberecht und die Kommunikationsvorschriften und -gesetze verstoßen. Die unbefugte Verwendung kann straf- und zivilrechtlich geahndet werden. Laszlo Sandor kann als Selbständiger Unterlassungs- und Schadensersatzansprüche geltend machen.